

CPD60/70/85/100 GB2D/GB2DLI



HELI



LI-ION 13000-22000lb
G3 Series Electric Battery
Forklift Truck



ANHUI HELI CO., LTD.

Add / No.668, FangXing Road, Hefei, China

Fax / +86-551-63639966

Tel / +86-551-63639068(America); 63639258(Europe);
63639358(Asia); 63662105(Africa & Middle East)



LinkedIn



YouTube



Facebook

Efficient and Energy saving

- Powerful dual drive, superior gradeability.

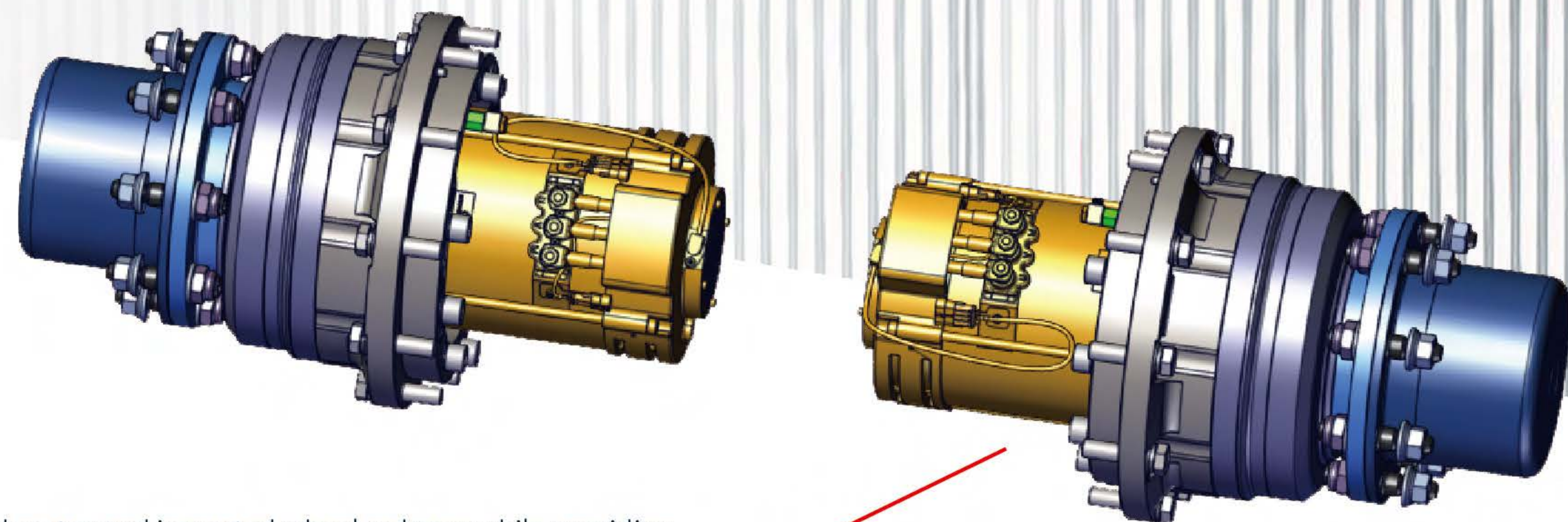

Dual drive power, imported motor and imported wheel reducer, while providing strong power, further improve the safety and stability of the truck.

Gradient
6-8.5t: **18%**
10t: **15%**

Intelligent and Safe

- Intelligent automatic parking:** optimized negative braking system and active parking in multiple applications are safe and easy which is safe and easy to make up omissions;
- Intelligent turning speed limit:** active speed limit function, balance efficiency and safety when turning at high speed;
- Intelligent limit buffer:** intelligent induction of mast lifting and lowering avoids limit impact and is safe and comfortable;
- Intelligent operation protection:** a full set of OPS system can avoid misoperation and ensure safety;
- Intelligent control strategy:** dual core controller is in line with the latest EU safety requirements.

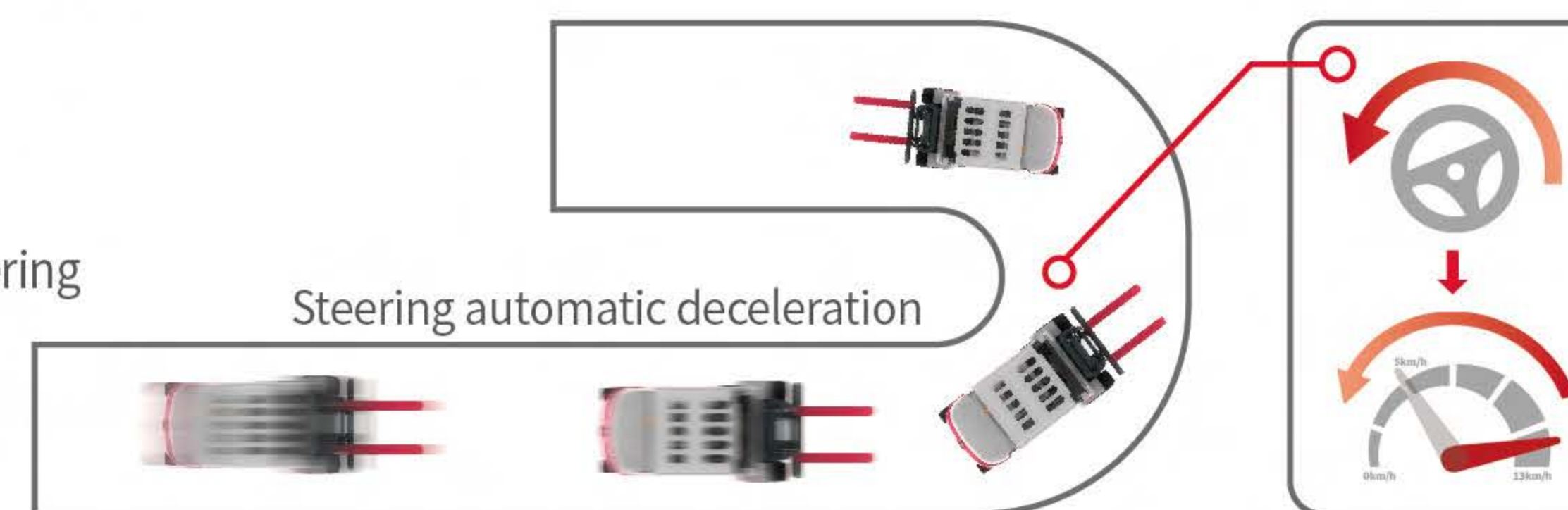

Driving speed: 6-7t: 9.4-10mph 8.5-10t: 8.1-9.7 mph	Maximum gradeability with load: 6-8.5t: 18% 10t: 15%	Maximum lifting speed with load: 13000-15500lb: 63ft/min 18500-22000lb: 50 ft/min	Maximum lifting speed without load: 0.46m/s 13000-15500lb: 91ft/min 18500-22000lb: 69ft/min	Good bearing capacity at high position

- Double gun charging, fast and efficient.

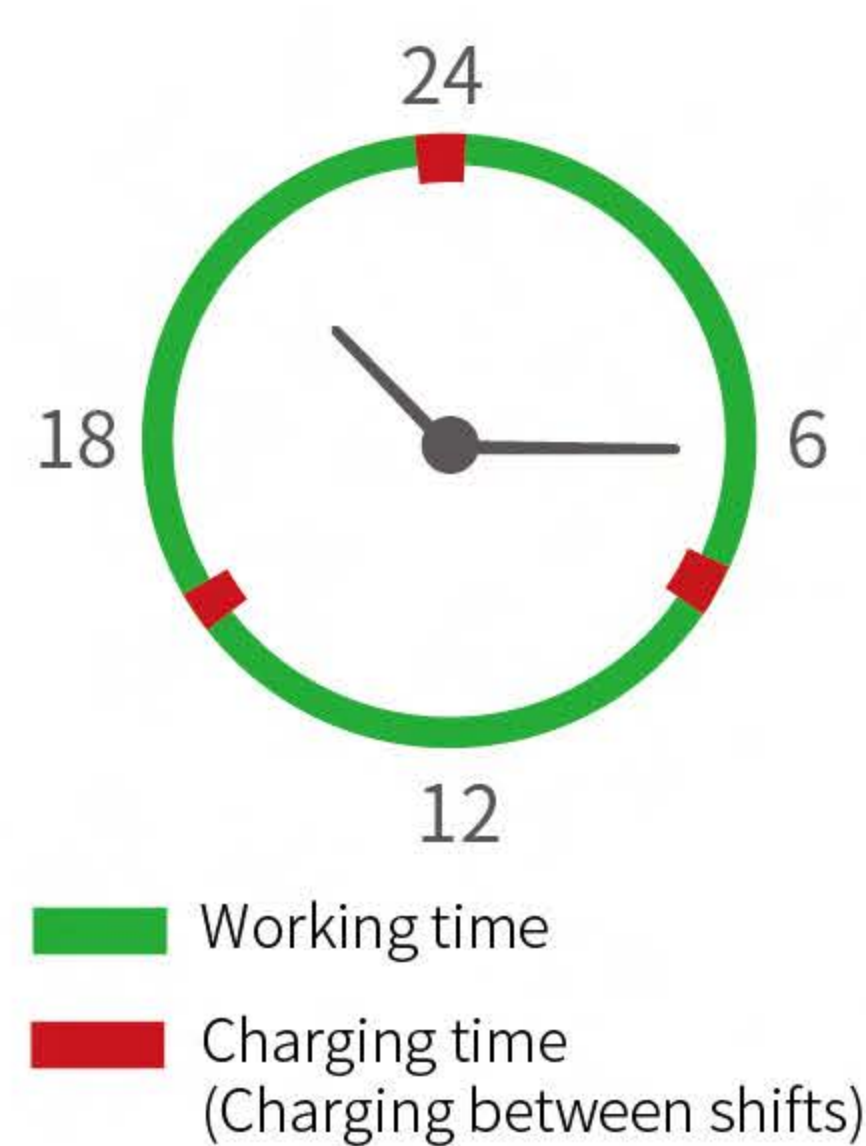

Lithium battery forklift truck is equipped with double gun charging as standard, which greatly reduces the charging time. Lithium batteries have high-density capability and can be used and charged at any time to realize efficient and continuous operation all day long.

Lithium battery options:

- 606Ah capacity (standard configuration):** which can be charged for 8 hours at one time, suitable for light load condition;
- 813Ah capacity:** one charge can meet 8-9 hours of operation, suitable for standard working conditions;
- 1084 Ah capacity:** one charge, suitable for 9-10 hours operation, suitable for heavy load strengthening conditions.
- 808Ah capacity (8.5-10t Lithium battery options):** one charge can meet 8-9 hours of operation, suitable for standard working conditions;

- Multi configuration, low energy consumption.

Parking brake button with two color model is easy to operate.	Independent steering system supplies oil for steering on demand and reduces truck energy consumption.	LED light of the whole truck has high brightness, long life and is more energy saving.	The front wheels are equipped with double tires as standard, with better carrying capacity.	Integrated fork positioner

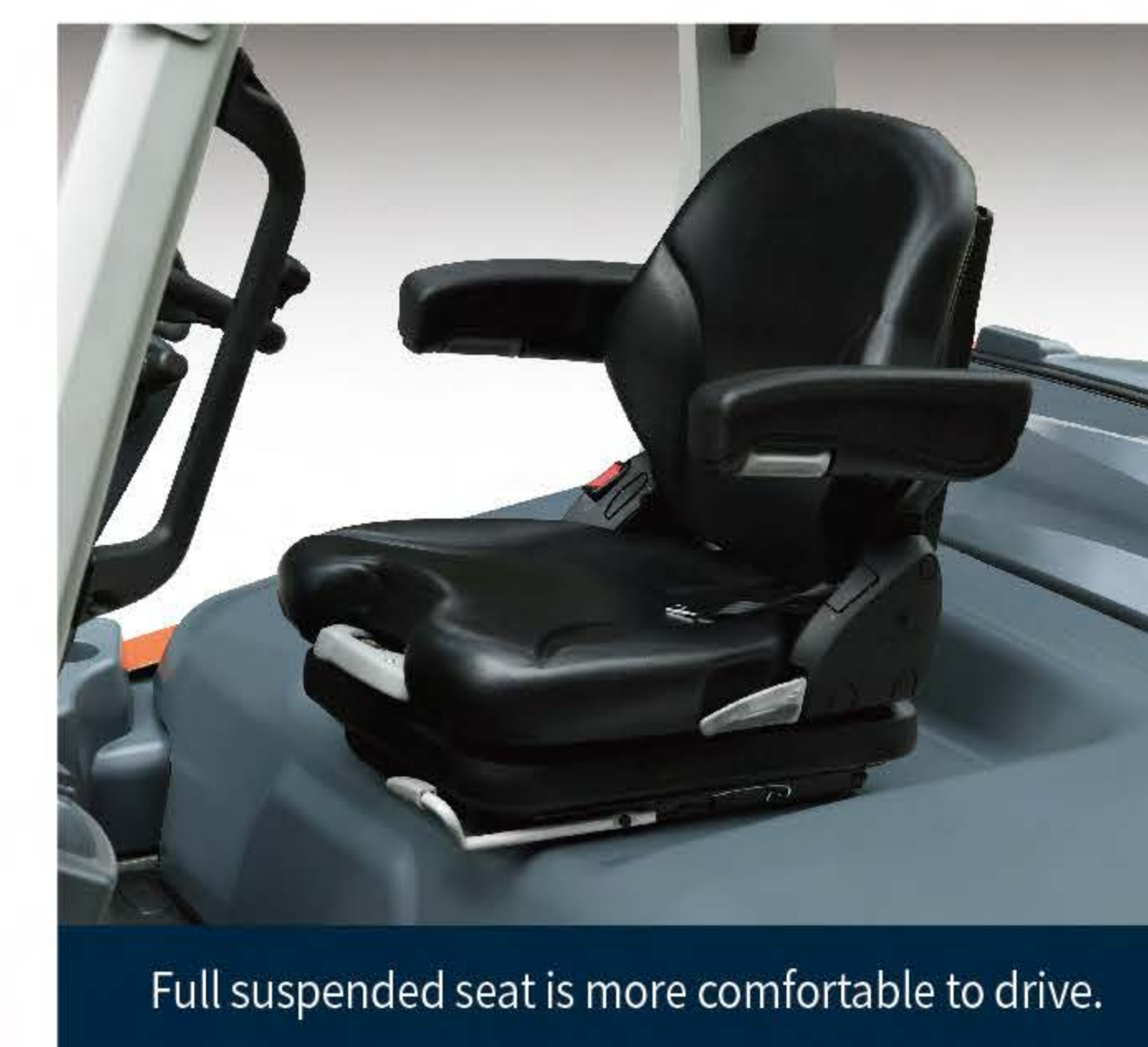
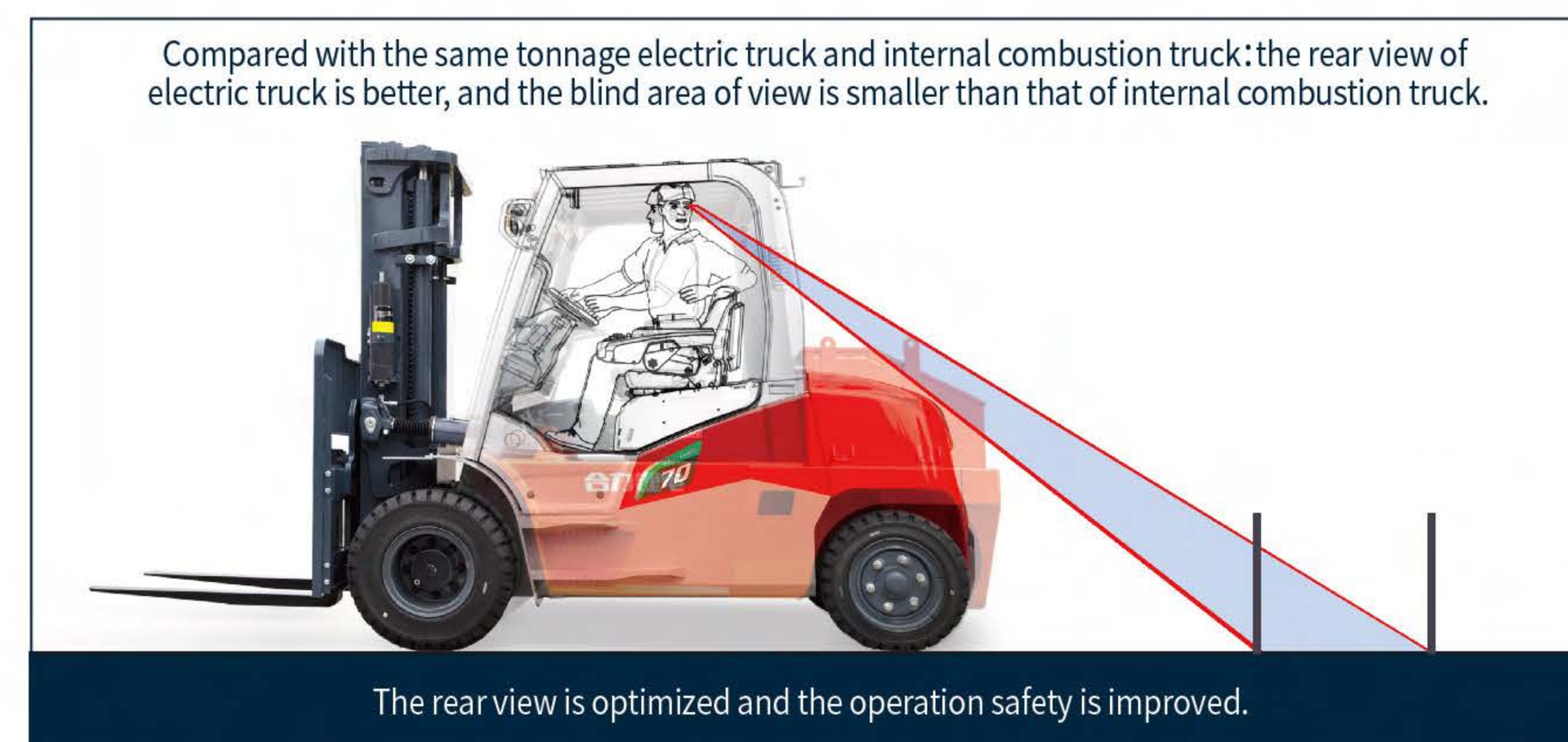
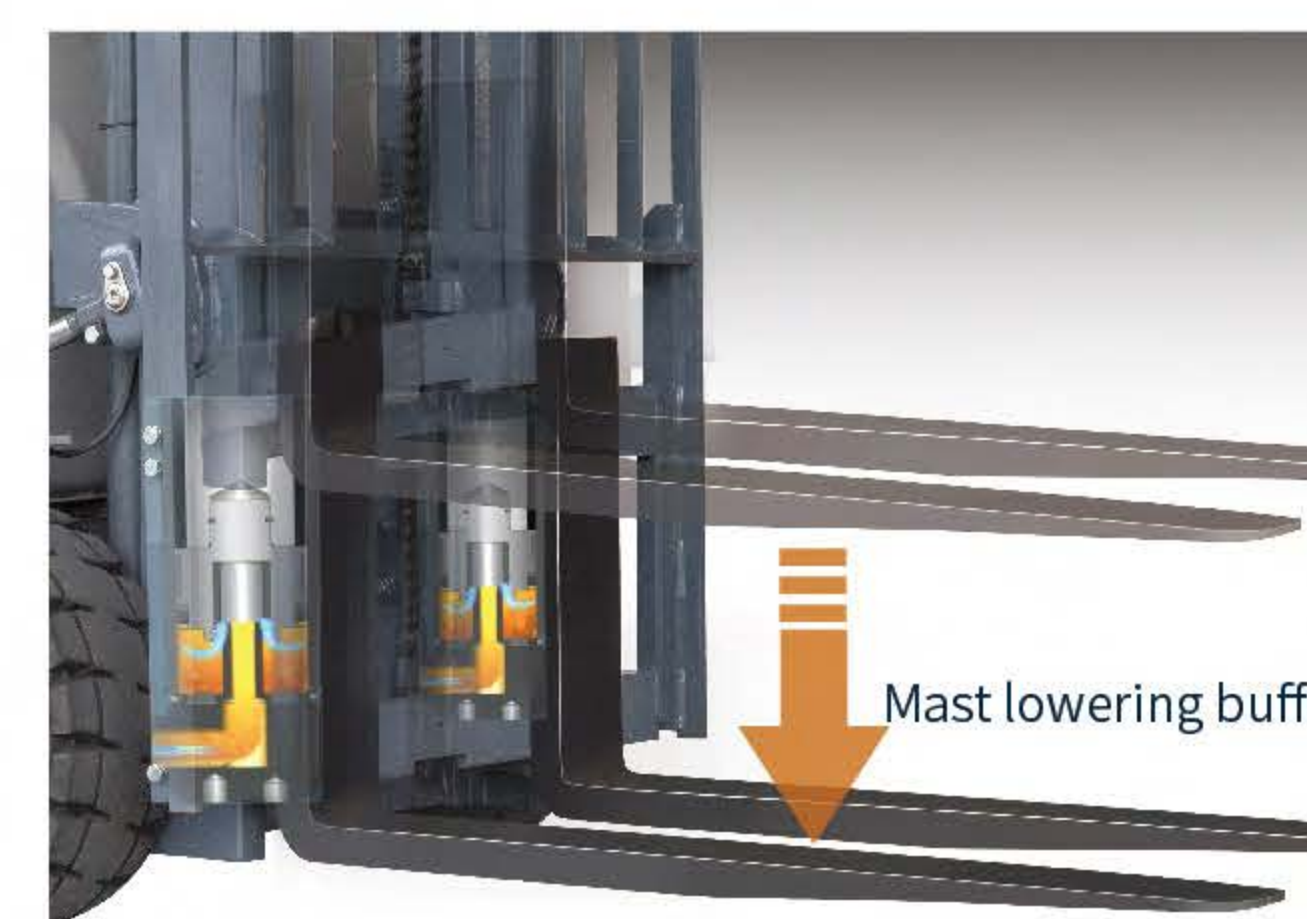

Comfort and Intimate

- The mast with large opening offers good driving vision ensuring operation comfort and safety.
- It integrates the advantages of internal combustion forklift truck platform to make the driving space more comfortable.
- Standard imported silent gear pump, greatly reduce the ear noise.



Optional configuration of intelligent safety buffer system cushion operator from effects of riding over uneven surface and it is more comfortable.

- **Vibration shock reduction**
When driving under load conditions, the impact caused by uneven surface is greatly absorbed, and the vibration is effectively reduced.
- **Vibration and noise reduction**
When driving under load condition, the impact noise caused by uneven surface is greatly reduced.
- **Reduced driving fatigue**
During the emergency stop operation during the load lowering process, the vibration and driving fatigue caused by inertia impact can be effectively reduced, and the driving safety can be improved.



- Hydraulic synchronous steering system can adjust steering wheel and wheel angle offset smartly and offers accurate steering and comfortable driving. (optional)
- Color screen display which can switch between Chinese and English, display truck speed, working time, battery power, fault code and other information.

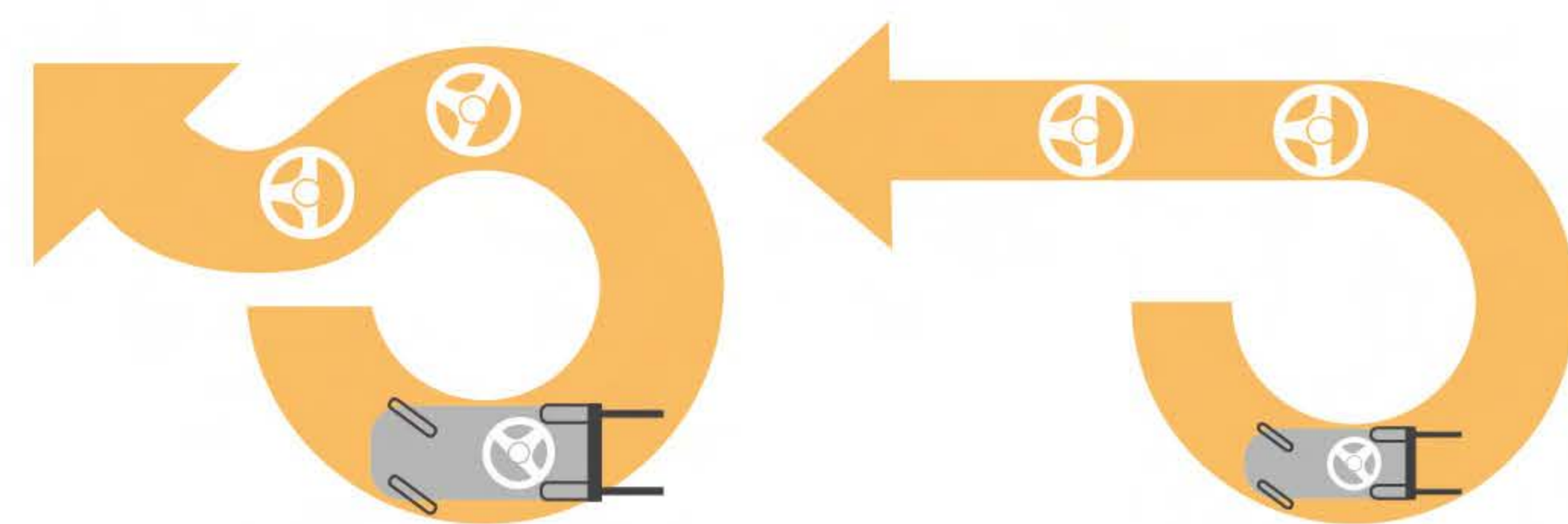

Without synchronous control function

With synchronous control function



Stable and Reliable

- Imported drive axle and motor are stable and reliable.
- Wet negative braking is safe and reliable.
- The innovative design of mast structure improves the overall strength and stiffness.
- The structural design of the welded large oil tank greatly improves the strength of the frame and the heat dissipation of the hydraulic oil.
- The whole truck can be operated alternately in -20°C cold storage for 6 hours and parked in the cold storage for 12 hours without failure and can continue to work.
- New design of steering axle is safe and reliable.



Convenient and Maintenance

- The layout of the cab is optimized, the battery is located directly under the engine room, and the hood opening angle is large, which facilitate daily inspection and maintenance.
- The controller is located on the counterweight, giving consideration to heat dissipation and maintenance convenience.
- The battery side changing is installed for easy changing between lead-acid battery and lithium battery as you like meet the needs of different customers and occasions.



HELI smart fleet management system(domestic basic edition)

Vehicle positioning	Statistical form
Remote diagnosis	Vehicle management
Remote monitoring	Identification recognition (optional)
Maintenance reminder	Weight management (optional)
Battery management	Collision management (optional)



Manufacturer and Technical Data (1)						
Characteristics						
1.01	Manufacturer			HELI		
1.02	Model		CPD60	CPD60	CPD60	CPD70
1.03	Configuration number		GB2D	GB2DLi	GB2DLi	GB2DLi
1.04	Rated capacity	Q	lb	13000	13000	15500
1.05	Load center distance	c	in	23.6		
1.06	Power mode			Electric		
1.07	Driving mode			Seated		
1.08	Front overhang	x	in	23.6	23.6	23.8
1.09	Wheelbase	y	in	90.7	90.7	90.7
Weight						
2.01	Total weight (with/without battery)		lb	23276/17490	21384/20174	21384/20174
2.02	Axle load (laden,front/rear)		lb	35970/2486	29519/2948	29519/2948
2.03	Axle load (unladen,front/rear)		lb	12606/10670	10450/10428	10450/10428
Tyres						
3.01	Tyre type			Solid tyre		
3.02	Tyre size,front			8.25-15		
3.03	Tyre size,rear			250-15		
3.04	Wheels,number front/rear (x=driven wheels)			4/x2		
3.05	Tread, front	b10	in	62		
3.06	Tread, rear	b11	in	54		
Dimensions						
4.01	Mast tilt angle (forward/backward)	α/β	$^{\circ}$	6/10		
4.02	Height (mast lowered)	h1	in	98		
4.03	Free lifting height	h2	in	6.3		6.5
4.04	Lifting height (standard)	h3	in	118		
4.05	Max. height,extended (with backrest)	h4	in	176		
4.06	Height of overhead guard	h6	in	98		
4.07	Seat height relating to SIP (to ground)	h7	in	57		
4.08	Towing coupling height	h10	in	19		
4.09	Overall length (with fork)	l1	in	183	183	183
4.10	Overall length (without fork)	l2	in	135	135	135
4.11	Overall width	b1	in	81		
4.12	Fork size:thickness x width x length	s/e/l	in	2.4/5.9/48	2.4/5.9/48	2.4/5.9/48
4.13	Fork carriage,according to ISO2328			4A		
4.14	Distance across fork-arms, Max./Min.	b5	in	72.6/11.8		
4.15	Distance across fork-arms, Max./Min.	m1	in	6.3		
4.16	Ground clearance (center of wheelbase)	m2	in	9.4		9
4.17	Right angle stacking aisle width for pallet 1000 x1200mm crossways	Ast	in	190.7		190.9
4.18	Right angle stacking aisle width for pallet 800 x1200mm lengthways	Ast	in	198.6		198.8
4.19	Min. outside turning radius	Wa	in	120		
Performance Data						
5.01	Travel speed (laden/unladen)		mph	9.3/9.9		
5.02	Lift speed (laden/unladen)		ft/min	68.9/90.5		63/90.5
5.03	Lowering speed (laden/unladen)		ft/min	90.5/88.6		94.5/88.6
5.04	Max.drawbar pull (laden/unladen)		lbf	7875	7875	8325
5.05	Max.gradeability (laden)		%	19	19	18
5.06	Acceleration time(10 m)(laden/unladen)		s	4.9/5.5	4.9/5.5	4.9/5.5
Battery						
6.01	Battery voltage/Capacity		V/Ah	80/840	80/606	80/606
6.02	Battery weight (Min./Max.)		lb	4730	1320	1320
6.03	Battery,according to DIN			DIN43536A		DIN43536A
Motor and controller						
7.01	Driving motor powering (S2-60min)		KW	2x17.1		
7.02	Lifting motor powering (S3-15%)		KW	2x26.5		
7.03	Driving motor controlling mode			MOSFET/AC		
7.04	Lifting motor controlling mode			MOSFET/AC		
Addition data						
8.01	Service brake/Parking brake			Hydraulic		
8.02	Operating pressure for attachments		Mpa	14		

Manufacturer and Technical Data (1)						
Characteristics						
1.01	Manufacturer			HELI		
1.02	Model			CPD85	CPD85	CPD100
1.03	Configuration number			GB2D	GB2DLi	GB2D
1.04	Rated capacity	Q	lb	18500	18500	22000
1.05	Load center distance	c	in	23.6		
1.06	Power mode			electric		
1.07	Driving mode			Seated		
1.08	Front overhang	x	in	25.6	25.6	26
1.09	Wheelbase	y	in	94.5	94.5	101.6
Weight						
2.01	Total weight (with/without battery)		lb	29964/24930	27852/27060	32516/27478
2.02	Axle load (laden,front/rear)		lb	43263/5357	41646/4939	49632/4884
2.03	Axle load (unladen,front/rear)		lb	15070/14938	13376/10428	16885/15631
Tyres						
3.01	Tyre type			Solid tyre		
3.02	Tyre size,front			8.25-15		
3.03	Tyre size,rear			250-15		
3.04	Wheels,number front/rear (x=driven wheels)			4/x2		
3.05	Tread, front	b10	in	66		
3.06	Tread, rear	b11	in	54		
Dimensions						
4.01	Mast tilt angle (forward/backward)	α/β	$^{\circ}$	6/9		
4.02	Height (mast lowered)	h1	in	106		116
4.03	Free lifting height	h2	in	7.9		8.3
4.04	Lifting height (standard)	h3	in	118		
4.05	Max. height,extended (with backrest)	h4	in	165		
4.06	Height of overhead guard	h6	in	97		
4.07	Seat height relating to SIP (to ground)	h7	in	57		
4.08	Towing coupling height	h10	in	18		
4.09	Overall length (with fork)	l1	in	192	192	199
4.10	Overall length (without fork)	l2	in	144	144	151
4.11	Overall width	b1	in	85		
4.12	Fork size:thickness x width x length	s/e/l	in	2.8/6.9/48	2.8/6.9/48	3.1/6.9/48
4.13	Fork carriage,according to ISO2328					
4.14	Distance across fork-arms, Max./Min.	b5	in	17.7-75.2		
4.15	Distance across fork-arms, Max./Min.	m1	in	9.4		
4.16	Ground clearance (center of wheelbase)	m2	in	9.7		
4.17	Right angle stacking aisle width for pallet 1000 x1200mm crossways	Ast	in	200		205
4.18	Right angle stacking aisle width for pallet 800 x1200mm lengthways	Ast	in	208		213
4.19	Min. outside turning radius	Wa	in	127	127	132
Performance Data						
5.01	Travel speed (laden/unladen)		mph	8.7/9.6		8.1/9.6
5.02	Lift speed (laden/unladen)		ft/min	59/77.8		50.2/68.9
5.03	Lowering speed (laden/unladen)		ft/min	84.6/84.6		84.6/68.9
5.04	Max.drawbar pull (laden/unladen)		lbf	9888		10112
5.05	Max.gradeability (laden)		%	18		15
5.06	Acceleration time(10 m)(laden/unladen)		s	5.38/5.84		4.9/5.5
Battery						
6.01	Battery voltage/Capacity		V/Ah	80/840	80/606	80/960
6.02	Battery weight (Min./Max.)		lb	5033	1760	5033
6.03	Battery,according to DIN			DIN43536A	-	DIN43536A
Motor and controller						
7.01	Driving motor powering (S2-60min)		KW	2x17.1		
7.02	Lifting motor powering (S3-15%)		KW	2x26.5		
7.03	Driving motor controlling mode			MOSFET/AC		
7.04	Lifting motor controlling mode			MOSFET/AC		
Addition data						
8.01	Service brake/Parking brake			Hydraulic		
8.02	Operating pressure for attachments		Mpa	14		

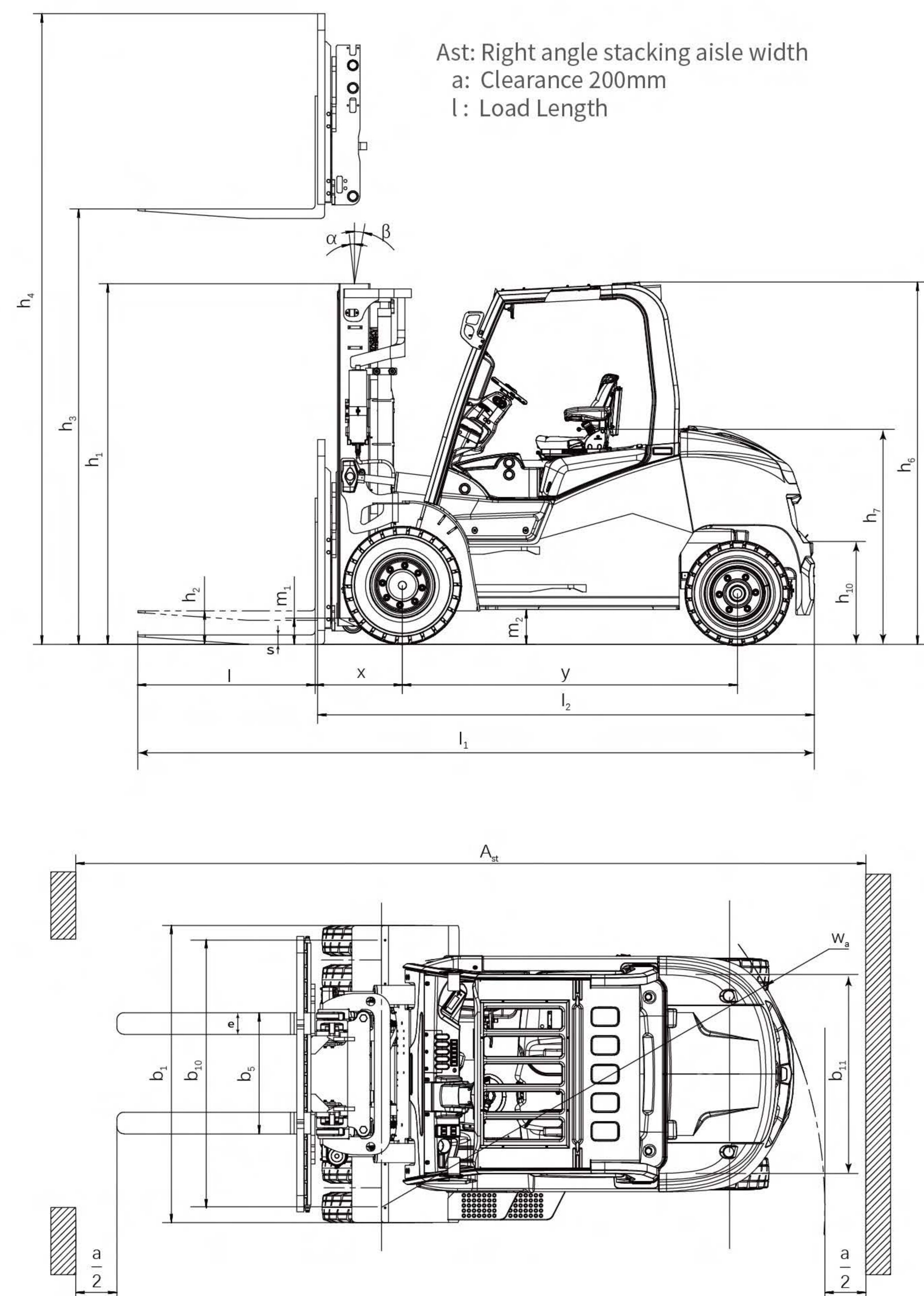

Operating Cost Comparison: Lithium battery forklift **vs.** Lead-acid battery forklift **vs.** IC forklift

The advantages of HELI lithium battery forklift trucks are more prominent in the life cycle cost.

Compared with internal combustion forklift truck, lithium battery forklift truck has the advantages of no noise, no pollution, small vibration and simple operation.

Compared with the lead-acid battery forklift truck, lithium battery forklift has the characteristics of fast charging and charging at any time, which is more suitable for multi shift operation.

Besides, HELI lithium battery forklift is maintenance free, high power conversion efficiency, and economical overall operation cost.

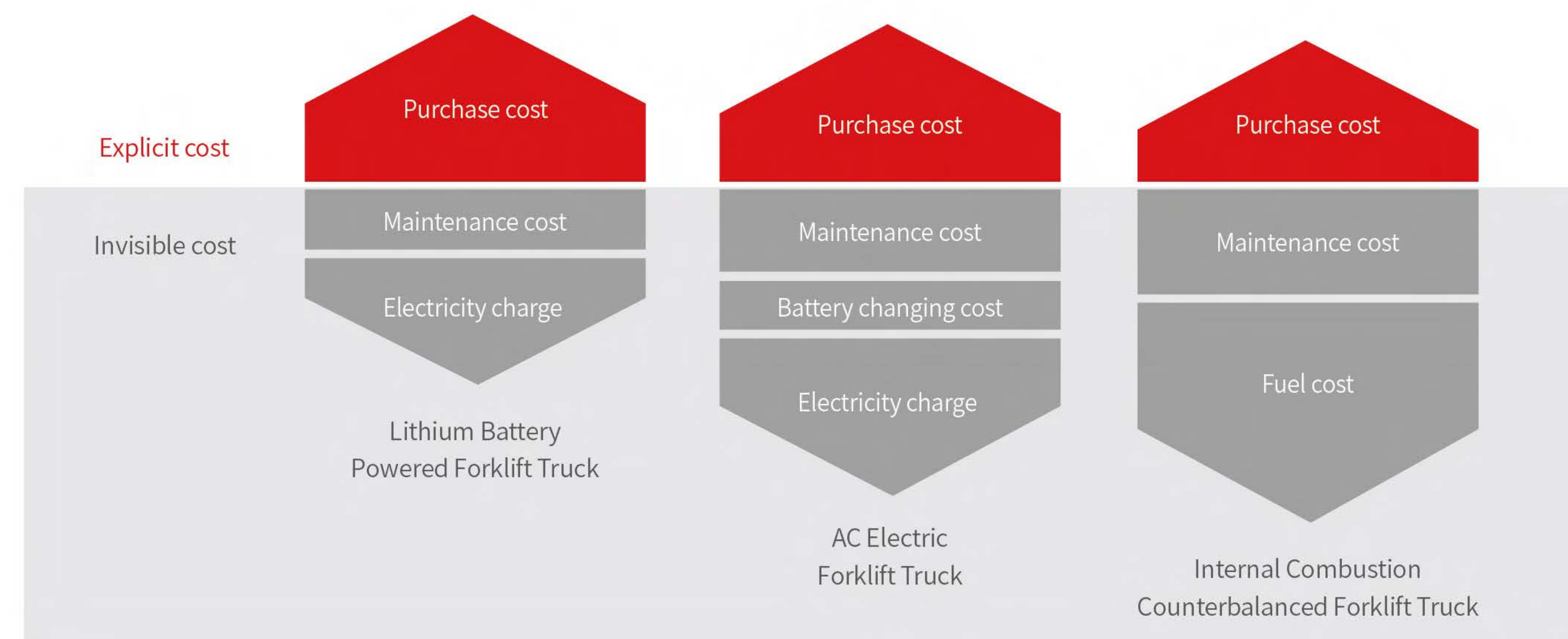

Lithium Battery Advantages

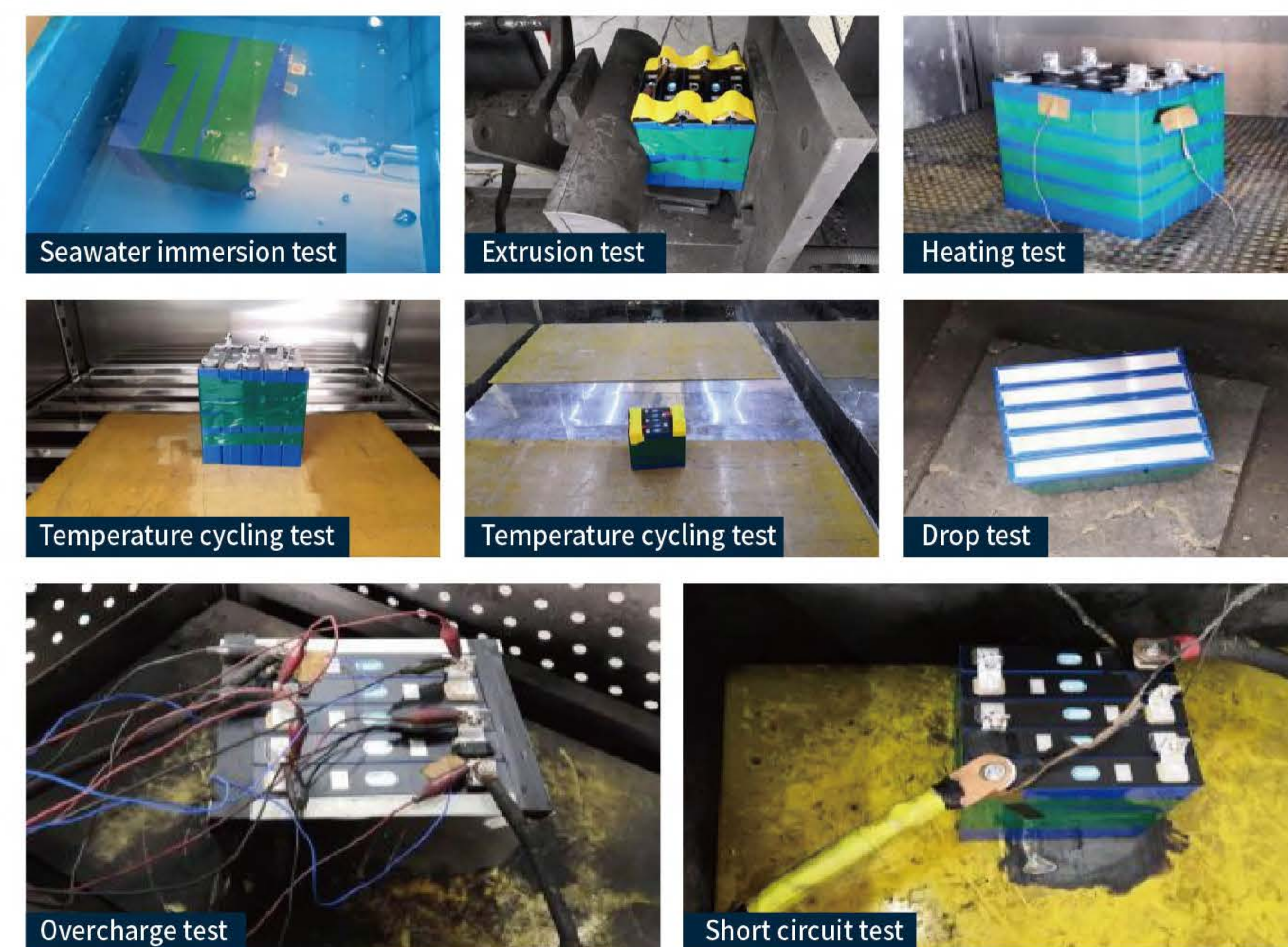

- ✓ The truck selects mature and economical square iron phosphate lithium battery core and module used by large numbers of commercial vehicles;
- ✓ The module adopts aluminum alloy plate frame, which is firm, light in weight and has good heat dissipation effect;
- ✓ Fast charging: fast charging makes truck gapless operation possible, and it can be fully charged in up to one hour;
- ✓ High efficiency and safety: The charging and discharging efficiency is up to 98%, and temperature of thermal runaway is over 600 °C;
- ✓ Low temperature adaptability: Standard configuration of heating function ensures normal operation of low temperature environment;
- ✓ Long service life: Over 75% capacity reserved after 5 years or ten thousand hours;
- ✓ Maintenance free: the battery does not need manual maintenance and does not need to add distilled water electrolyte;
- ✓ Green and clean: no pollution and zero emission.

Load curve



CPD60-GB2D CPD70-GB2D CPD85-GB2D(Li)
 CPD60-GB2DLi CPD70-GB2DLi CPD100-GB2D(Li)

Note: The vertical axis stands for load capacity and the horizontal axis stands for load center which is calculated from the front surface of the forks to the gravity of the standard load. The standard load means a cubic with 1000mm edge length. When mast is tilted forward, using non-standard forks or loading large goods, the load capacity will be reduced. The load capacity of standard mast at different load center can be known from this load chart.

G3 6-7t Wide View Standard Mast

Mast model	Max. lifting height (in)	Load capacity (lode center 24 in)(lb)				Height (mast lowered) (in)		Free lift(with backrest) (in)		Service weight (lb)				Mast tilt angle α/β(deg)
		CPD60-GB2D	CPD60-GB2DLI	CPD70-GB2D	CPD70-GB2DLI	CPD60-GB2D/GB2DLI	CPD70-GB2D/GB2DLI	CPD60-GB2D/GB2DLI	CPD70-GB2D/GB2DLI	CPD60-GB2D	CPD60-GB2DLI	CPD70-GB2D	CPD70-GB2DLI	
M220	87	13000	13000	15500	15500	81.9	6.5	23034	21120	24024	22462	6/10		
M250	98	13000	13000	15500	15500	87.8	6.5	23122	21208	24112	22550	6/10		
M270	106	13000	13000	15500	15500	91.7	6.5	23188	21274	24178	22616	6/10		
M300	118	13000	13000	15500	15500	97.6	6.5	23276	21384	24266	22726	6/10		
M330	130	13000	13000	15500	15500	103.5	6.5	23342	21450	24332	22792	6/10		
M350	138	13000	13000	15500	15500	107.5	6.5	23408	21516	24398	22858	6/10		
M400	157	13000	13000	15500	15500	119.3	6.5	23804	21912	24794	23254	6/10		
M425	167	13000	13000	15500	15500	124.2	6.5	23870	21978	24860	23320	6/10		
M450	177	13000	13000	15500	15500	129.1	6.5	23958	22044	24948	23386	6/10		
M475	187	13000	13000	15500	15500	134.1	6.5	24046	22132	25036	23474	6/5		
M500	197	13000	13000	15500	15500	139.0	6.5	24112	22198	25102	23540	6/5		
M550	217	12540	12980	14520	14960	150.8	6.5	24508	22594	25498	23936	6/5		
M600	236	11800	12320	14080	14520	160.6	6.5	24640	22726	25630	24068	6/5		

G3 8.5-10t Wide View Standard Mast

Mast model	Max. lifting height (in)	Load capacity (lode center 24 in)(lb)		Height (mast lowered)(in)		Service weight (lb)				Mast tilt angle α/β (deg)
		CPD85	CPD100	CPD85	CPD100	CPD85-GB2D	CPD85-GB2DLI	CPD100-GB2D	CPD100-GB2DLI	
M250	98	18500	22000	96.5	106.3	28246	26354	31924	30670	6/9
M270	106	18500	22000	100.4	110.2	28367	26475	32012	30758	6/9
M300	118	18500	22000	106.3	116.1	29742	27850	32190	30936	6/9
M330	130	18500	22000	110.2	122.0	29964	28072	32296	31042	6/9
M350	138	18500	22000	116.1	126.0	30283	28391	32395	31141	6/9
M375	148	18500	22000	121.1	130.9	30547	28655	32505	31251	6/9
M400	157	18500	22000	128.0	137.8	30932	29040	32813	31559	6/9
M425	167	18500	22000	132.9	142.7	31273	29381	32934	31680	6/9
M450	177	18500	22000	137.8	147.6	31537	29645	33044	31790	6/9
M475	187	18040	22000	142.7	152.6	31856	29964	33169	31915	6/6
M500	197	18040	22000	147.6	157.5	32109	30217	33290	32036	6/6
M550	217	17270	19800	159.4	169.3	32817	30925	33953	32699	6/6
M600	236	16280	17600	169.3	179.1	33264	31372	34063	32809	6/6

G3 6-7t Wide View Full Free 2-Stage Mast

Mast model	Max. lifting height (in)	Load capacity (lode center 24 in)(lb)				Height (mast lowered) (in)		Free lift(with backrest) (in)		Service weight (lb)				Mast tilt angle α/β(deg)
		CPD60-GB2D	CPD60-GB2DLI	CPD70-GB2D	CPD70-GB2DLI	CPD60-GB2D/GB2DLI	CPD70-GB2D/GB2DLI	CPD60-GB2D/GB2DLI	CPD70-GB2D/GB2DLI	CPD60-GB2D	CPD60-GB2DLI	CPD70-GB2D	CPD70-GB2DLI	
ZM220	87	13000	13000	15500	15500	81.1	28.0	23254	21340	24310	22748	6/10		
ZM250	98	13000	13000	15500	15500	87.0	33.9	23353	21439	24409	22847	6/10		
ZM270	106	13000	13000	15500	15500	90.9	37.8	23430	21516	24486	22924	6/10		
ZM300	118	13000	13000	15500	15500	96.9	43.7	23529	21637	24585	23045	6/10		
ZM330	130	13000	13000	15500	15500	102.8	49.6	23606	21714	24662	23122	6/10		
ZM350	138	13000	13000	15500	15500	106.7	53.5	23683	21791	24739	23199	6/10		
ZM400	157	13000	13000	15500	15500	118.5	65.4	24090	22198	25146	23606	6/10		
ZM425	167	13000	13000	15500	15500	123.4	70.3	24167	22275	25223	23683	6/10		
ZM450	177	13000	13000	15500	15500	128.3	75.2	24266	22352	25322	23760	6/10		
ZM475	187	13000	13000	15500	15500	133.3	80.1	24365	22451	25421	23859	6/5		
ZM500	197	13000	13000	15500	15500	138.2	85.0	24442	22528	25498	23936	6/5		
ZM550	217	12540	12980	14520	14960	150.0	96.9	24849	22935	25905	24343	6/5		
ZM600	236	11800	12320	14080	14520	159.8	106.7	24992	23078	26048	24486	6/5		

G3 8.5-10t Wide View Full Free 2-Stage Mast

Mast model	Max. lifting height (in)	Load capacity (lode center 24 in)(lb)		Height (mast lowered)(in)		Free lift (with backrest)(in)		Service weight (lb)				Mast tilt angle α/β (°)
		CPD85	CPD100	CPD85	CPD100	CPD85	CPD100	CPD85-GB2D	CPD85-GB2DLI	CPD100-GB2D	CPD100-GB2DLI	
ZM250	98	18700	22000	96.5	106.3	49	48	29843	27953	33521	30670	6/9
ZM270	106	18700	22000	100.4	110.2	53	51	29900	28010	33609	30758	6/9
ZM300	118	18700	22000	106.3	116.1	59	57	29993	28103	33697	30846	6/9
ZM330	130	18700	22000	110.2	122.0	65	63	30083	28193	33873	31022	6/9
ZM350	138	18700	22000	116.1	126.0	69	67	30144	28255	33950	31099	6/9
ZM375	148	18700	22000	121.1	130.9	74	71	30221	28332	34060	31209	6/9
ZM400	157	18700	22000	128.0	137.8	81	78	30523	28633	34368	31517	6/9
ZM425	167	18700	22000	132.9	142.7	85	83	30598	28708	34489	31638	6/9
ZM450	177	18700	22000	137.8	147.6	90	88	30675	28785	34599	31748	6/9
ZM475	187	18040	20900	142.7	152.6	95	93	30752	28862	34731	31880	6/6
ZM500	197	18040	20900	147.6	157.5	100	98	30763	28873	34846	31995	6/6
ZM550	217	17270	19800	159.4	169.3	112	110	31207	29317	35506	32655	6/6
ZM600	236	16280	17600	169.3	179.1	122	120	31359	29469	35611	32760	6/6

G3 6-7t Wide View Full Free 3-Stage Mast

Mast model	Max. lifting height (in)	Load capacity (lode center 24 in)(lb)				Height (mast lowered) (in)		Free lift(with backrest) (in)		Service weight (lb)				Mast tilt angle α/β (deg)
		CPD60-GB2D	CPD60-GB2DLI	CPD70-GB2D	CPD70-GB2DLI	CPD60-GB2D/GB2DLI	CPD70-GB2D/GB2DLI	CPD60-GB2D/GB2DLI	CPD70-GB2D/GB2DLI	CPD60-GB2D	CPD60-GB2DLI	CPD70-GB2D	CPD70-GB2DLI	
ZSM360	142	12320	12650	13640	13970	92.5	36.2	24376	21758	25366	23100	6/5		
ZSM400	157	12320	12650	13640	13970	96.9	41.1	24508	21890	25498	23232	6/5		
ZSM435	171	12320	12650	13640	13970	101.8	46.1	24618	22000	25608	23342	6/5		
ZSM450	177	12320	12650	13640	13970	103.7	48.0	24684	22066	25674	23408	6/5		
ZSM480	189	12320	12650	13640	13970	107.9	52.2	24794	22176	25784	23518	6/5		
ZSM500	197	12320	12650	13640	13970	112.2	54.7	24860	22242	25850	23584	6/5		
ZSM540	213	11660	11990	13200	13530	115.7	60.0	24992	22374	25982	23716	6/5		
ZSM600	236	11000	11330	12320	12650	123.4	67.7	25190	22572	26180	23914	6/5		
ZSM650	256	9900	10230	11000	11330	134.1	78.3	25366	22748	26356	24090	6/5		
ZSM700	276	8800	9130	9900	10230	138.2	82.5	25542	22924	26532	24266	6/5		

G3 8.5-10t Wide View Full Free 3-Stage Mast

Mast model	Max. lifting height (in)	Load capacity (lode center 600mm) (kg)		Height (mast lowered)(in)		Free lift (with backrest)(in)		Service weight (lb)				Mast tilt angle α/β (°)
		CPD85	CPD100	CPD85	CPD100	CPD85	CPD100	CPD85-GB2D	CPD85-GB2DLI	CPD100-GB2D	CPD100-GB2DLI	
ZSM360	142	16500	17600	96.5	101.2	48.6	46.5	31150	29260	34949	32556	6/9
ZSM400	157	16500	17600	101.4	106.3	53.5	51.6	31306	29416	35152	32758	6/9
ZSM435	171	16500	17600	106.3	111.0	58.5	56.3	31469	29359	35328	32934	6/9
ZSM450	177	16500	17600	108.3	113.0	60.4	58.3	31528	29638	35416	33022	6/9
ZSM480	189	15840	16500	112.2	116.9	64.4	62.2	31662	29773	35565	33172	6/6
ZSM500	197	15840	16500	116.1	119.5	68.3	64.8	31786	29896	35666	33273	6/6
ZSM540	213	14960	15400	121.1	127.0	73.2	72.2	31948	30059	35961	33627	6/6
ZSM600	236	13860	14300	132.9	134.8	85.0	80.1	32325	30435	36269	33876	6/6

Note: Free lifting height of shelf without stop 6t:+13.4in,7t:+7.1in

Compatible in system, Special in style

----- It is rather to achieve mutual achievement
than give an ostentatious display of ability.

Compatible Lithium battery and lead acid
battery are optional as you like.

Integrated Combine the humanization design advantages of both
internal combustion forklift truck and electric truck.



The truck is a continuation of HELI family style and creates a new concept of electric forklift
through easy exchange between lead acid battery power and lithium battery power